

1.4/1.6t Mast Specification

Type	Lifting height h ₁	Mast lowered h ₂	Mast extended h ₃	Free lifting height h ₄	Tilting range α/β
	mm	mm	mm	mm	(°)
Wide view duplex mast	2700	1950	3665	105	2/5
	3000	2100	3965	105	2/5
	3300	2250	4265	105	2/5
	3500	2350	4465	105	2/5
	3600	2400	4565	105	2/5
	4000	2650	4965	105	2/5
	4300	2790	5265	105	2/5
	4500	2900	5465	105	2/5
	4800	3095	5765	105	2/5
	5000	3195	5965	105	2/5
Full free triple mast	4000	2930	4965	1065	2/5
	4500	2160	5465	1185	2/5
	5000	2300	5965	1335	2/5
	5500	2450	6465	1485	2/5
	6000	2625	6965	1660	2/5
	6500	2800	7465	1835	2/5
	7000	3000	7965	2035	2/5
	7500	3060	8465	2095	2/5
	8000	3250	8965	2285	2/5
	8500	3420	9465	2455	2/5
	9000	3580	9965	2615	2/5
	9500	3760	10465	2795	2/5
	10000	3920	10965	2955	2/5
	10500	4100	11465	3135	2/5
	11000	4300	11965	3335	2/5

1.8t Mast Specification

Type	Lifting height h ₁	Mast lowered h ₂	Mast extended h ₃	Free lifting height h ₄	Tilting range α/β
	mm	mm	mm	mm	(°)
Wide view duplex mast	2700	1950	3665	110	2/5
	3000	2100	3965	110	2/5
	3300	2250	4265	110	2/5
	3500	2350	4465	110	2/5
	3600	2400	4565	110	2/5
	4000	2650	4965	110	2/5
	4300	2790	5265	110	2/5
	4500	2900	5465	110	2/5
	4800	3095	5765	110	2/5
	5000	3195	5965	110	2/5
Full free triple mast	4000	2085	4965	1120	2/5
	4500	2165	5465	1200	2/5
	5000	2315	5965	1350	2/5
	5500	2490	6465	1525	2/5
	6000	2665	6965	1700	2/5
	6500	2835	7465	1870	2/5
	7000	3020	7965	2055	2/5
	7500	3180	8465	2215	2/5
	8000	3350	8965	2385	2/5
	8500	3500	9465	2515	2/5
	9000	3600	9965	2635	2/5
	9500	3770	10465	3005	2/5
	10000	4100	10965	3135	2/5
	10500	4250	11465	3285	2/5
	11000	4450	11965	3485	2/5
11500	4700	12465	3735	2/5	

2.0t Mast Specification

Type	Lifting height h ₁	Mast lowered h ₂	Mast extended h ₃	Free lifting height h ₄	Tilting range α/β
	mm	mm	mm	mm	(°)
Wide view duplex mast	2700	1950	3665	110	2/5
	3000	2100	3965	110	2/5
	3300	2250	4265	110	2/5
	3500	2350	4465	110	2/5
	3600	2400	4565	110	2/5
	4000	2650	4965	110	2/5
	4300	2790	5265	110	2/5
	4500	2900	5465	110	2/5
	4800	3095	5765	110	2/5
	5000	3195	5965	110	2/5
Full free triple mast	4000	2085	4965	1120	2/5
	4500	2165	5465	1200	2/5
	5000	2315	5965	1350	2/5
	5500	2490	6465	1525	2/5
	6000	2665	6965	1700	2/5
	6500	2835	7465	1870	2/5
	7000	3020	7965	2055	2/5
	7500	3180	8465	2215	2/5
	8000	3350	8965	2385	2/5
	8500	3500	9465	2515	2/5
	9000	3600	9965	2635	2/5
	9500	3770	10465	3005	2/5
	10000	4100	10965	3135	2/5
	10500	4250	11465	3285	2/5
	11000	4450	11965	3485	2/5
11500	4700	12465	3735	2/5	
12000*	4900	12965	3935	2/5	
12500*	5150	13465	4185	2/5	
13000*	5400	13965	4435	2/5	

* When you choose the mast, the dimensions of the truck will be affected. Please refer to the performance parameter table for details.

2.5t Mast Specification

Type	Lifting height h ₁	Mast lowered h ₂	Mast extended h ₃	Free lifting height h ₄	Tilting range α/β
	mm	mm	mm	mm	(°)
Wide view duplex mast	2700	1950	3665	110	2/5
	3000	2100	3965	110	2/5
	3300	2250	4265	110	2/5
	3500	2350	4465	110	2/5
	3600	2400	4565	110	2/5
	4000	2650	4965	110	2/5
	4300	2790	5265	110	2/5
	4500	2900	5465	110	2/5
	4800	3095	5765	110	2/5
	5000	3195	5965	110	2/5
Full free triple mast	4000	2085	4965	1120	2/5
	4500	2165	5465	1200	2/5
	5000	2315	5965	1350	2/5
	5500	2490	6465	1525	2/5
	6000	2665	6965	1700	2/5
	6500	2835	7465	1870	2/5
	7000	3020	7965	2055	2/5
	7500	3180	8465	2215	2/5
	8000	3350	8965	2385	2/5
	8500	3500	9465	2515	2/5
	9000	3600	9965	2635	2/5
	9500	3770	10465	3005	2/5
	10000	4100	10965	3135	2/5
	10500	4300	11465	3335	2/5
	11000	4500	11965	3535	2/5
11500	4800	12465	3835	2/5	
12000*	5000	12965	4035	2/5	
12500*	5300	13465	4335	2/5	
13000*	5600	13965	4635	2/5	

* When you choose the mast, the dimensions of the truck will be affected. Please refer to the performance parameter table for details.

Maahantuonti:

Finnsiirto Oy
www.finnsiirto.fi



ZHEJIANG HANGCHA IMP. & EXP. CO., LTD.

Factory site: 666 Xiangfu Road,
Hangzhou, Zhejiang, China (311305)

Tel: +86-571-88926735 88926755
Fax: +86-571-88926789 88132890

sales@hcforklift.com
www.hcforklift.com



Follow us on
Facebook



Follow us on
YouTube



Follow us on
WeChat



Download "Hangcha
Forklift" App



ISO14001
ISO14001:2015



ISO9001
ISO9001:2015



HANGCHA trucks conform to the European Safety Requirements.

HANGCHA GROUP CO., LTD. reserves the right to make any changes without notice concerning colors, equipment, or specifications detailed in this brochure, or to discontinue individual models. The colors of trucks, delivered may differ slightly from those in brochures.

2023 VERSION 5/COPYRIGHT 2023/08



XC-SARJA LITHIUM-ION TYÖNTÖMASTOTRUKIT

1400 - 2500 kg



The World of Hangcha
SINCE 1956



KORKEALAATUISTA SUORITUSKYKYÄ JA ERGONOMIAA

XC-SARJAN TYÖNTÖMASTOTRUKKI LI-ION -AKULLA

- / Litiumvoimalla varustetut XC-sarjan työntömastotrukit hyödyntävät litiumakun edut ja omaavat useita innovaatioita trukin rakenteessa, toiminnallisessa ratkaisussa, suorituskykyparametreissa, ergonomiassa ja käyttäjän näkymässä. Työntömastomallis soveltuu lukuisiin käyttökohteisiin samalla varmistaen optimaalisen energiatehokkuuden.
- / Huolehdimme erityisvaatimuksistasi – ahtaat tilat tai jopa 13 metrin nostokorkeus, jopa 2500 kg:n nostotarpeet tai yksilöllinen ominaisuuksien räätälöinti eri vaihtoehdoilla – Hangcha on oikea valinta!
- / Litiumakun kompakti koko ja perinteisen rakennesuunnittelun uudistaminen tekevät XC-mallistosta moderneimman ja tehokkaimman työntömastotrukin logistiikan markkinoilla.

MAX AJONOPEUS

14km/h

MAX NOSTONOPEUS

0.81m/s

MAX KUORMITUS

6,500mm

MAX NOSTOKYKY

2,500kg

MAX NOSTOKORKEUS

13,000mm



YMPÄRISTÖ- YSTÄVÄLLINEN TEHOKAS JA KESTÄVÄ

- / 80V CATL/EVE -litium-ion -akku on vakiona kaikissa kokoluokissa. Se tarjoaa pikalatauksen ja pitkän käyttöiän sekä vähemmän energianhäviöitä.
- / Erikoismuotoiltu litiumakkupaketti tarjoaa suuren käyttötilan ohjaamoon ja laajan näkymän joka puolelle.



Latausportti



Akun sijainti

 Työaika **> 10h**

 Pikavaraus **≤ 2h**

Akkukapasiteetit		
1.4 t	Std.	80V/250Ah
1.6 t		
1.8 t		
2.0 t	Opt.	80V/404Ah
2.5 t		

Huom: Std. 80V/250Ah, Work time > 6h;
Opt. 80V/404Ah, Work time > 10h



TYYLIKÄS MUOTOILU JA KOMPAKTI DESIGN

KULJETTAJAN ALUE LAADUKKAILLA MATERIAALEILLA
JA ÄLYKKÄILLÄ RATKAISUILLA.



Akkutilan muotoilu ja runkorakenteen ansiosta kuljettajalla on ylivoimaisen laaja näkymä.



Erityisesti kehitetty mastorakenne takaa hyvän näkyvyyden.

/ Hydraulikkalinja ja mastorakenne limittyvät, joka kasvattaa läpinäkyvyyttä.

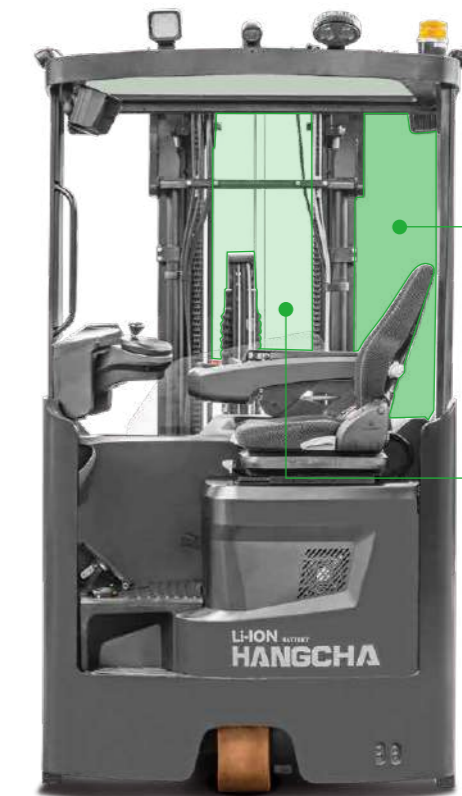

Kompakti mastorakenne mahdollistaa hyvän näkyvyyden maston uolkopuolelle.

Keskisynteri on sijoitettu epäkeskisesti, jotta kuljettajalla on paras näkyvyys.

YKSITYISKOHTAISESTI HUOLITeltu ERGONOMINEN MUOTOILU

Informaationäytön asennon säätö



Asennonsäätö



Lattiatason sähkösäätö eripituisille kuljettajille

Laadukas merkki-istuin

Moderni Fingertip -
hallinta

MONIPUOLINEN INFORMAATIO- VÄRINÄYTTÖ

Helppokäyttöinen 4,3" värinäyttö on suunniteltu erityisesti työntömastotrukkien käyttöön.



Kattavaa ja ajankohtaista tietoa kuljettajalle



1

1. Nostokorkeus
2. Kello
3. Kuormitus

2

1. Ajomoodi
2. Käyttötunnit
Korkeusnäyttö

3

1. Ohjausmoodi
2. Akun varaus
3. Ajonopeus

4

Tilannekohtaiset
merkki -ja
varoitusalot

Nopea hallinta ja käyttö

Valintapainikkeet ovat sijoitettu loogisesti ja selkein merkinnöin.



5

Nostokorkeuden
valinta

6

Nostokorkeuden
rajoitin

7

Valaistus

8

Akun irrotus

9

Optio näytölle

10

↑ Ajomoodin
valinta

11

↓ Hidasajo

MONIPUOLISTA TYÖSKENTELYÄ



Nostokorkeuden valinta

Näyttöön voidaan esiasettaa useita eri nostokorkeuksia nostotyön nopeuttamiseksi. Haarukat pysähtyvät pehmeällä loppuhidastuksella asetettuun korkeuteen.

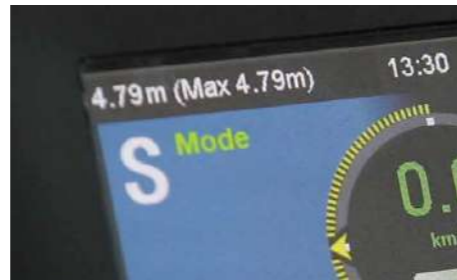

Nostokorkeuden rajoitus

Nostokorkeuden rajoittimella voidaan sallia korkein mahdollinen haarukoiden nostokorkeus. Näin vältetään esimerkiksi matalan tilan katto/ rakennevaurioilta.

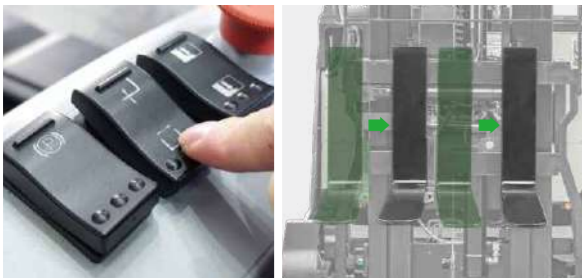

Automaattinen sivuttaisiirto

Yksinkertaista ja nopeaa, sivusiirron keskiasemointi tapahtuu automaattisesti (vain Fingertip)

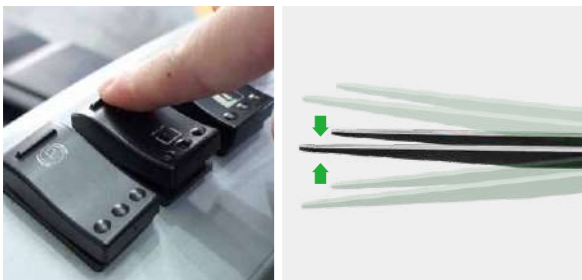

Haarukoiden/maston keskikallistus

Haarukoiden keskikallistus nopeasti napin painalluksella (vain Fingertip)



Nopea ja helppo maston hallinta

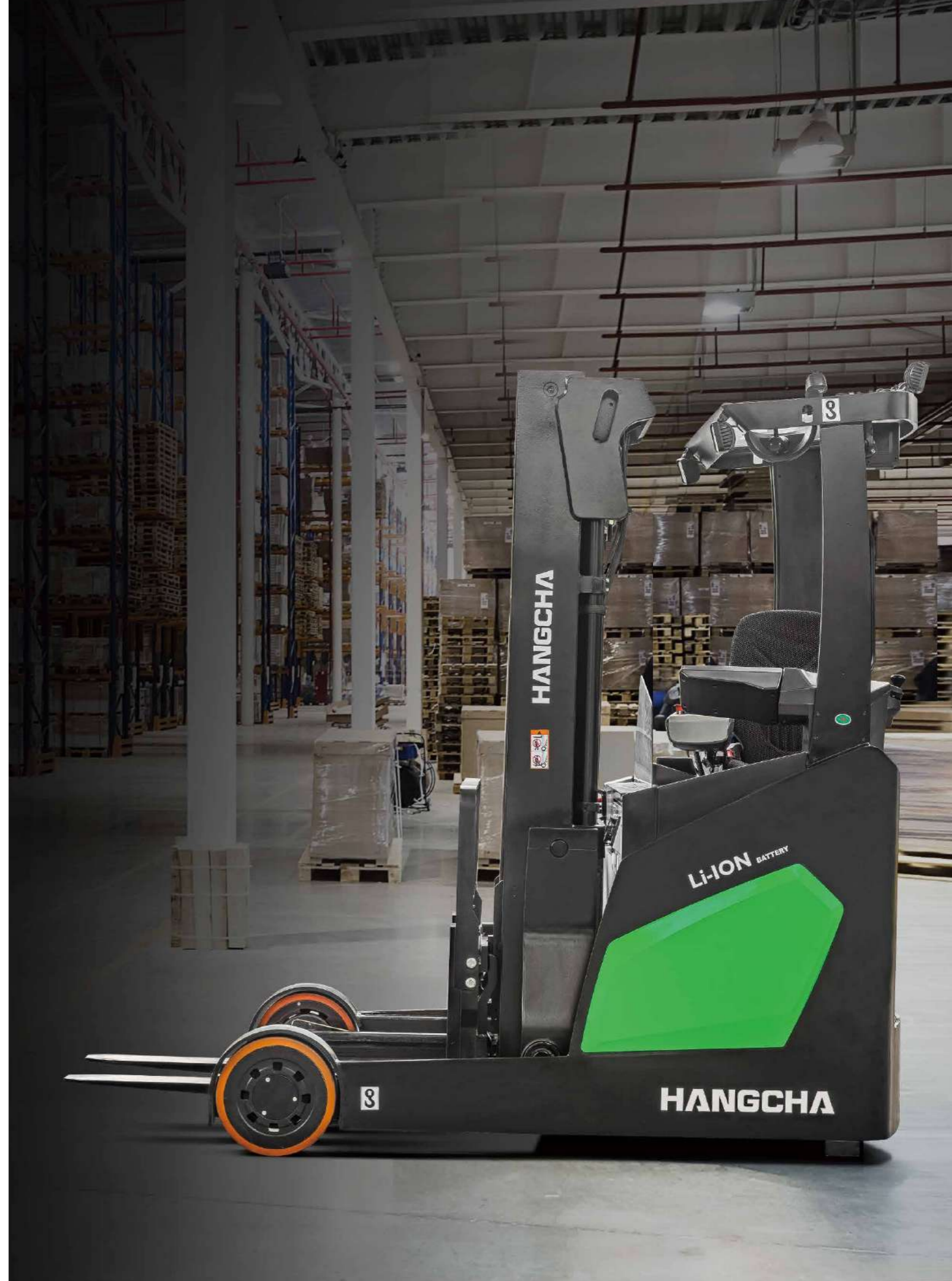

TURVALLISUUTTA JOKAISESTA NÄKÖKULMASTA

Ajo-ohjaus rajoittaa ajonopeutta ja ajonopeutta heti, kun haarukat nostetaan. Tämä lisää turvallisuutta siirrettäessä nostettu lava hyllyn edessä, mutta varmistaa silti herkemman ohjaamisen aikana.

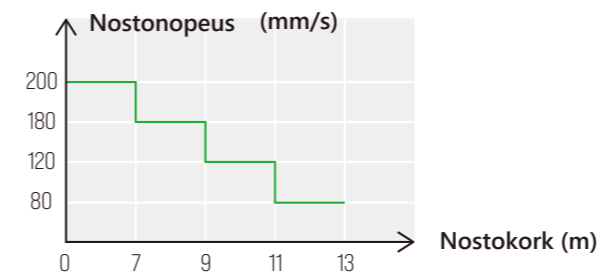

Yllä oleva koskee malleja 2-2.5T

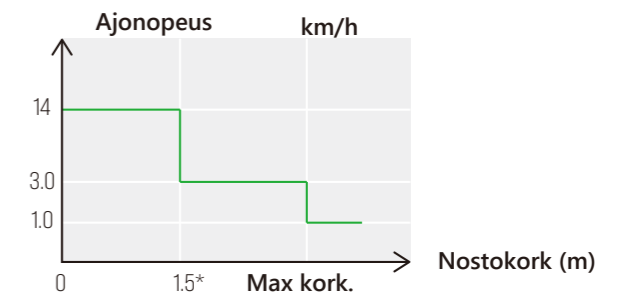

*: 1,5 m on vain Fingertip -järjestelmälle. Mekaanisen ohjausjärjestelmän parametri on vapaan noston korkeus.



Tarkasta akuston lukitus

Akuston lukitusjärjestelmä

Kytкин valvoo akuston kiinnityssalppaa. Jos akkua ei ole vedetty sisään tai lukittu, on ajonopeus rajoitettu.



HELPPOA HUOLLETTAVUUTTA

Akuston voi vaihtaa tarvittaessa nopeasti. Kuljettaja voi avata lukituksen istuessaan.



Akuston lukitus



Maston työntö eteenpäin



Akun irroitus

Huoltoluukku on helppo avata rutiinihuoltotoimenpiteiden suorittamiseksi.



Kiinnikkeet



Kotelon irroitus



Pääkomponentit helposti esillä

Istuin kääntyy suureen kulmaan, jotta huoltotyöt voidaan suorittaa nopeasti.



Kääntyvä istuin



Suurempi avauskulma

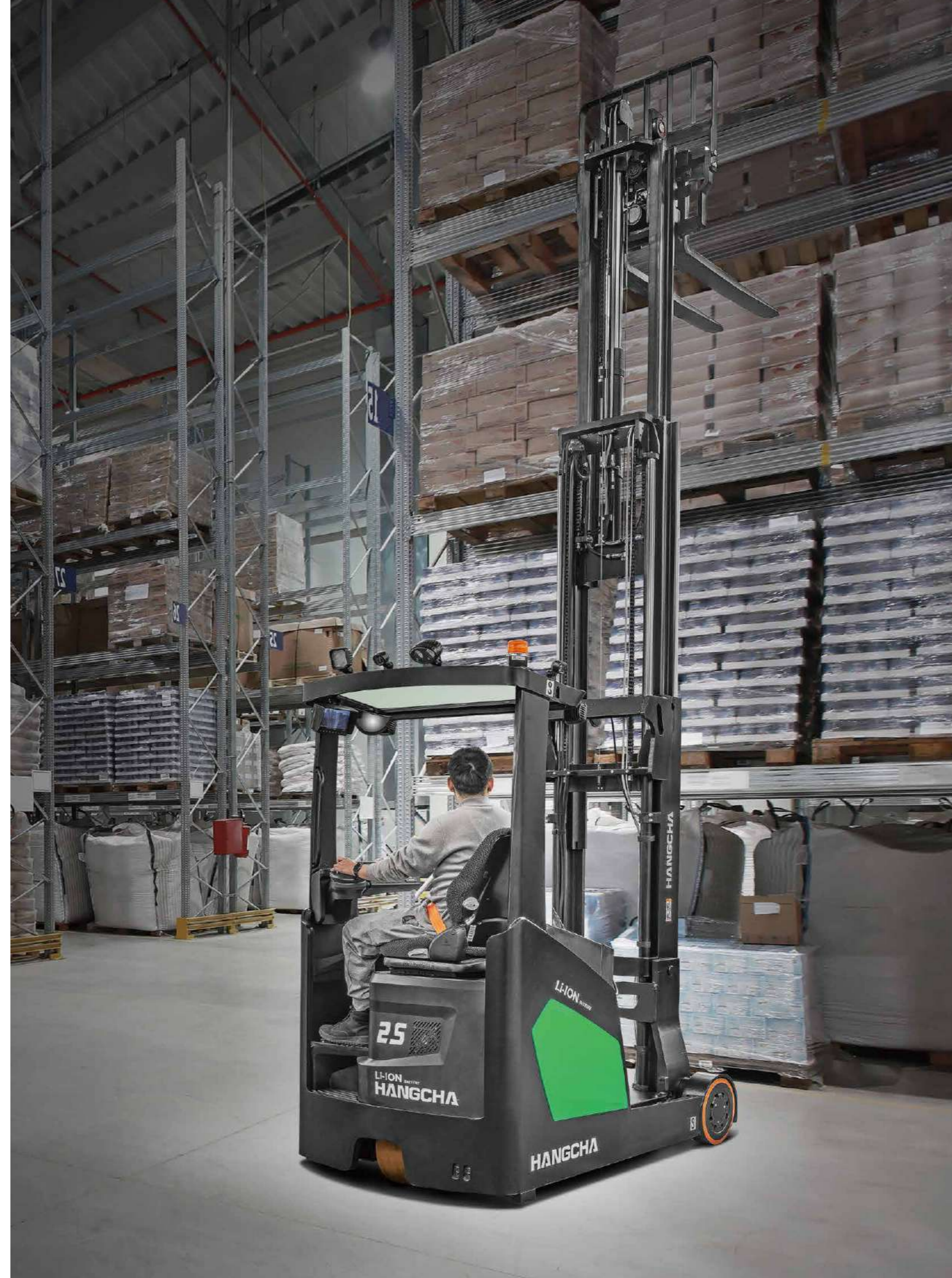

KATTAVA LISÄVARUSTELU



Hyllytys kameran avulla

Haarukkakamera mahdollistaa tarkan ja nopean pääsyn erittäin korkeisiin paikkoihin. Kameran asento haarukoissa mahdollistaa sen, että käyttäjät voivat tehokkaasti ja luotettavasti ohjata pinoamista ja noutoa istuma-asennostaan/näkökulmastaan. Heidän ei enää tarvitse katsoa ylöspäin, mikä vähentää huomattavasti hartioiden ja kaulan rasitusta. Myös laivojen tiedot ovat helposti näkyvissä, jopa suurella korkeudella.

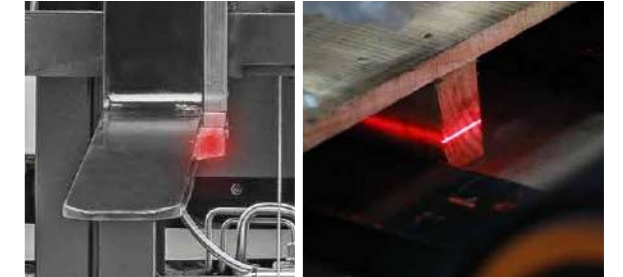

Laserosoitin

Paikannuslaserimme yksinkertaistavat merkittävästi pinoamista ja noutoprosessia ja lisäävät kuorman ja hyllytön turvallisuutta. Laserlähde on integroitu haarukkaan, mikä heijastaa punaisen viivan edessä olevalle alueelle. Näin kuljettaja voi säätää haarukkaa tarkemmin, ja ohjata suoraan halutulle korkeudelle.



Helppo käytöhallinta

Helppo pääsy suojaa työntömastotrukkia luvattomalta käytöltä. Valtuutuksen hallintaa ohjataan suoraan trukin näytön kautta. Räätelöity tarpeidesi ja yrityksen koon mukaan – voit valita avaimen (vakio), PIN-koodin ja kortin välillä.



Turvallisuutta näkyvyydellä

Työturvallisuusvalo heijastaa edellä kulkevan huomiota herättävän valopisteen. Ominaisuudella on merkittävä turvallisuushyöty risteysalueilla ja kuormatelineiden päätyalueilla.



100 % näkyvyys panoramakatolla

Paras näkyvyys: Panoraamakattopaneeli ilman poikkipalkkeja tarjoaa maksimaalisen näkyvyyden kuormalle ja haarukoille.



Optimaalinen pito luistonestojärjestelmällä

Optimaalinen pito varmistetaan vetopyörän jarrutuksella, joka muuten luistaisi märillä tai pölyisillä latioilla.



XC TYÖNTÖMASTOTRUKKI KYLMAVARASTO- KÄYTTÖÖN

(jopa -30C käyttöympäristöissä)



Etu-, taka-, ylä- ja sivuikkunat on valmistettu laaja-alaisesta karkaistusta lasista, ja niissä on vakiona etu-, taka- ja yläikkunanpyyhkimet kuljettajan näkyvyyden parantamiseksi.

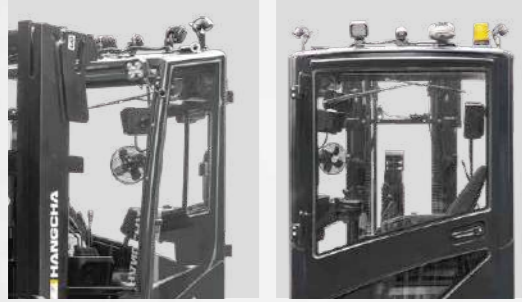

Tehokas lämmitin ohjaamon lämpötilan nostamiseksi. Ohjaamon lämpötila voidaan nostaa 10 °C:seen -30 °C:n kylmävarastokäytössä.



Täysin suljetulla ohjaamolla varustetulla hytillä on erinomainen ruosteesto-, oikosulku-, vesieristys- ja eristyskyky, täyttäen -30 °C:n käyttöympäristön vaatimukset.



-30.0





Features

NO.	System	Features	CQD14/16/18/20/25-XC5-SI*	CQD14/16/18/20/25-XC50-SI*	CQD14/16/18/20/25-XC5-SIJS*	CQD14/16/18/20/25-XC50-SIJS*
1	Applicable environment	Cold storage model [-18 °C]	<input type="radio"/>	<input type="radio"/>	<input checked="" type="radio"/>	<input checked="" type="radio"/>
2		Cold storage model [-30 °C]	<input type="radio"/>	<input type="radio"/>	<input checked="" type="radio"/>	<input checked="" type="radio"/>
3		Full closed cab	/	/	<input checked="" type="radio"/>	<input checked="" type="radio"/>
4	Control	Control with a mechanical control lever	<input checked="" type="radio"/>	/	<input checked="" type="radio"/>	/
5		Control with a fingertip switch	/	<input checked="" type="radio"/>	/	<input checked="" type="radio"/>
6		Height display	<input type="radio"/> (Only for triplex mast, excluding the free lift range)	<input checked="" type="radio"/> (Including the free lift range)	<input type="radio"/> (Only for triplex mast, excluding the free lift range)	<input checked="" type="radio"/> (Including the free lift range)
7		Height selection	<input type="radio"/> (Only for triplex mast, excluding the free lift range)	<input checked="" type="radio"/> (Including the free lift range)	<input type="radio"/> (Only for triplex mast, excluding the free lift range)	<input checked="" type="radio"/> (Including the free lift range)
8		Height limit	<input type="radio"/> (Only for triplex mast, excluding the free lift range)	<input checked="" type="radio"/> (Including the free lift range)	<input type="radio"/> (Only for triplex mast, excluding the free lift range)	<input checked="" type="radio"/> (Including the free lift range)
9		Central sideshift	/	<input type="radio"/>	/	<input type="radio"/>
10		Horizontal fork alignment	/	<input type="radio"/>	/	<input type="radio"/>
11		Mast reach damping system	<input checked="" type="radio"/>	<input checked="" type="radio"/>	<input checked="" type="radio"/>	<input checked="" type="radio"/>
12		Electric lowering limit - Stop forks above outriggers if mast is retracted	<input type="radio"/>	<input checked="" type="radio"/>	<input type="radio"/>	<input type="radio"/>
13		Soft landing system	/	<input type="radio"/>	/	<input type="radio"/>
14		Lifting damping system	<input checked="" type="radio"/>	<input checked="" type="radio"/>	<input checked="" type="radio"/>	<input checked="" type="radio"/>
15		Drive control limit	<input checked="" type="radio"/>	<input checked="" type="radio"/>	<input checked="" type="radio"/>	<input checked="" type="radio"/>
16	Drive wheel skid control system	<input type="radio"/>	<input type="radio"/>	<input type="radio"/>	<input type="radio"/>	
17	Battery lock with creep speed interlock	<input checked="" type="radio"/>	<input checked="" type="radio"/>	<input checked="" type="radio"/>	<input checked="" type="radio"/>	
18	Travelling speed control at corner	<input checked="" type="radio"/>	<input checked="" type="radio"/>	<input checked="" type="radio"/>	<input checked="" type="radio"/>	
19	180° steering mode	<input checked="" type="radio"/>	<input checked="" type="radio"/>	<input checked="" type="radio"/>	<input checked="" type="radio"/>	
20	360° steering mode	<input type="radio"/>	<input type="radio"/>	<input type="radio"/>	<input type="radio"/>	
21	Transmission system	ZF transmission	<input checked="" type="radio"/>	<input checked="" type="radio"/>	<input checked="" type="radio"/>	<input checked="" type="radio"/>
22	Electronic accessories	USB power socket	<input checked="" type="radio"/>	<input checked="" type="radio"/>	<input checked="" type="radio"/>	<input checked="" type="radio"/>
23		Fork video monitoring and positioning laser	<input type="radio"/>	<input type="radio"/>	<input type="radio"/>	<input type="radio"/>
24		Keyed start	<input checked="" type="radio"/>	<input checked="" type="radio"/>	<input checked="" type="radio"/>	<input checked="" type="radio"/>
25		Start with a PIN code or by a card	<input type="radio"/>	<input type="radio"/>	<input type="radio"/>	<input type="radio"/>
26		Beep	<input type="radio"/>	<input type="radio"/>	<input type="radio"/>	<input type="radio"/>
27		Operating light (in the direction of the fork)	<input checked="" type="radio"/>	<input checked="" type="radio"/>	<input checked="" type="radio"/>	<input checked="" type="radio"/>
28		Operating light (in the reverse direction of the fork)	<input type="radio"/>	<input type="radio"/>	<input type="radio"/>	<input type="radio"/>
29		Alarm light	<input checked="" type="radio"/>	<input checked="" type="radio"/>	<input checked="" type="radio"/>	<input checked="" type="radio"/>
30		Blue light	<input type="radio"/>	<input type="radio"/>	<input type="radio"/>	<input type="radio"/>
31		Three-sided one line laser projection light	<input type="radio"/>	<input type="radio"/>	<input type="radio"/>	<input type="radio"/>
32		Reading light in the car	/	/	<input checked="" type="radio"/>	<input checked="" type="radio"/>
33		Double -speed wind speed heater	/	/	<input type="radio"/>	<input type="radio"/>
34		Electric fan	<input type="radio"/>	<input type="radio"/>	<input type="radio"/>	<input type="radio"/>
35		The front window glass double -speed wiper	/	/	<input checked="" type="radio"/>	<input checked="" type="radio"/>
36	Back window glass double -speed wiper	/	/	<input checked="" type="radio"/>	<input checked="" type="radio"/>	
37	Top window glass double -speed wiper	/	/	<input checked="" type="radio"/>	<input checked="" type="radio"/>	
38	Front window glass spray water	/	/	<input checked="" type="radio"/>	<input checked="" type="radio"/>	
39	Ergonomic design	Electrical adjustment of pedal height	<input type="radio"/>	<input type="radio"/>	<input type="radio"/>	<input type="radio"/>
40		Adjustable steering wheel	<input checked="" type="radio"/>	<input checked="" type="radio"/>	<input checked="" type="radio"/>	<input checked="" type="radio"/>
41	Instrument angle adjustment	<input checked="" type="radio"/>	<input checked="" type="radio"/>	<input checked="" type="radio"/>	<input checked="" type="radio"/>	
42	Fault Diagnosis	Suctioned oil filter clogging alarm	<input type="radio"/>	<input type="radio"/>	<input type="radio"/>	<input type="radio"/>
43		Backflow oil filter clogging alarm	<input type="radio"/>	<input checked="" type="radio"/>	<input type="radio"/>	<input checked="" type="radio"/>
44	Seat	Sequential Seat Belt Interlock System	<input checked="" type="radio"/>	<input checked="" type="radio"/>	<input checked="" type="radio"/>	<input checked="" type="radio"/>
45		BF6-3 suspension seat	<input checked="" type="radio"/>	/	<input checked="" type="radio"/>	/
46	MS665/522 suspension seat	<input type="radio"/>	<input checked="" type="radio"/>	/	<input checked="" type="radio"/>	
47	Other	Panorama roof	<input type="radio"/>	<input type="radio"/>	<input checked="" type="radio"/>	<input checked="" type="radio"/>
48		PVC ceiling	<input type="radio"/>	<input type="radio"/>	/	/
49		The side glass can be opened	/	/	<input checked="" type="radio"/>	<input checked="" type="radio"/>
50		Broken window	/	/	<input checked="" type="radio"/>	<input checked="" type="radio"/>
51		Moving the side of the battery	<input type="radio"/>	<input type="radio"/>	<input type="radio"/>	<input type="radio"/>
52		Curved rearview mirror	<input type="radio"/>	<input type="radio"/>	<input type="radio"/>	<input type="radio"/>
53		Left and right rear view mirrors	<input type="radio"/>	<input type="radio"/>	/	/
54		Load backrest	<input checked="" type="radio"/>	<input checked="" type="radio"/>	<input checked="" type="radio"/>	<input checked="" type="radio"/>
55	Fire extinguisher	<input type="radio"/>	<input type="radio"/>	<input type="radio"/>	<input type="radio"/>	
56	OPS system	<input checked="" type="radio"/>	<input checked="" type="radio"/>	<input checked="" type="radio"/>	<input checked="" type="radio"/>	

Note: ● Standard; ○ Optional
★ CE model

XC Series Reach Truck With Lithium Power Specification

Distinguishing mark	1.1	Manufacturer	HANGCHA GROUP CO.,LTD.					
	1.2	Model	CQD14-XC5-SI* CQD14-XC5D-SI*	CQD16-XC5-SI* CQD16-XC5D-SI*	CQD18-XC5-SI* CQD18-XC5D-SI*	CQD20-XC5-SI* CQD20-XC5D-SI*	CQD25-XC5-SI* CQD25-XC5D-SI*	
1.3	Power unit		Li-Ion battery	Li-Ion battery	Li-Ion battery	Li-Ion battery		
1.4	Manual		Seated	Seated	Seated	Seated		
1.5	Rated capacity/rated load	Q(t)	1.4	1.6	1.8	2	2.5	
1.6	Load centre distance	c(mm)	600	600	600	600	600	
1.8	Load distance	x(mm)	360 ¹⁷⁾	410 ¹⁷⁾	385 ¹⁸⁾	362 ²⁰⁾	484 ²⁰⁾	
1.8.1	Load distance, mast reached forward	x1(mm)	211 ²⁾	211 ²⁾	203	232	232	
1.9	Wheelbase	y(mm)	1355	1405	1405	1471	1601	
Weight	2.1	Net weight incl. battery (see row 6.5)	(kg)	3330	3370	3370	3470	3620
Tyres, chassis	3.1	Tyres		PU	PU	PU	PU	PU
	3.2	Tyre size, front		φ343×140	φ343×140	φ343×140	φ343×140	φ400×160
	3.3	Tyre size, rear		φ285×100	φ285×100	φ285×100	φ343×108	φ343×108
	3.5	Wheels, number front/rear (x = driven wheels)		1x/2	1x/2	1x/2	1x/2	1x/2
	3.7	Tread width, rear	b11(mm)	1174	1174	1174	1162	1162
Dimensions	4.1	Tilt of fork carriage forward/backward	α/β(°)	2.0/5.0	2.0/5.0	2.0/5.0	2.0/5.0	2.0/5.0
	4.2	Height, mast lowered	h1(mm)	2100	2100	2100	2100	2100
	4.3	Free lift	h2(mm)	105	105	110	110	110
	4.4	Lift	h3(mm)	3000	3000	3000	3000	3000
	4.5	Height, mast extended	h4(mm)	3965	3965	3965	3965	3965
	4.7	Height of overhead guard	h6(mm)	2263	2263	2263	2263	2263
	4.8	Seat height	h7(mm)	1159	1159	1159	1159	1159
	4.10	Height of support arms	h8(mm)	308	308	308	365.5	365.5
	4.19	Overall length	h(mm)	2400 ³⁾	2400 ³⁾	2425 ⁷⁾	2514 ²¹⁾	2542 ²¹⁾
	4.20	Length to face of forks	l2(mm)	1250 ³⁾	1250 ³⁾	1275 ⁷⁾	1364 ²¹⁾	1392 ²¹⁾
	4.21	Overall width	b1/b2(mm)	1270/1270	1270/1270	1270/1270	1270/1270	1270/1270
	4.22	Fork dimensions	s/e/l(mm)	40×122×1150 ²⁵⁾	40×122×1150 ²⁵⁾	40×122×1150	40×122×1150	40×122×1150
	4.23	Fork carriage ISO 2328, class/type A, B		II A	II A	II A	II A	II A
	4.24	Fork-carriage width	b3(mm)	830	830	830	830	830
	4.25	Distance between fork-arms	b5(mm)	750	750	750	750	750
	4.26	Distance between wheel arms	b4(mm)	940	940	940	940	940
	4.28	Reach distance	l4(mm)	571 ⁴⁾	621 ⁴⁾	588 ⁸⁾	594 ²⁰⁾	716 ²⁰⁾
	4.32	Ground clearance, centre of wheelbase	m2(mm)	80	80	80	80	80
	4.33	Aisle width for pallets 1000 × 1200 sideways	Ast1(mm)	2687 ⁵⁾	2701 ⁵⁾	2719 ⁸⁾	2802 ²¹⁾	2867 ²⁴⁾
	4.34	Aisle width for pallets 800 × 1200 lengthways	Ast2(mm)	2740 ⁶⁾	2745 ⁶⁾	2768 ⁸⁾	2855 ²¹⁾	2896 ²⁵⁾
4.35	Turning radius	Wa(mm)	1610	1660	1660	1726	1876	
4.37	Length over the support arms	l1(mm)	1775	1825	1825	1920	2070	
Performance data	5.1	Travel speed, laden/unladen	(km/h)	14/14	14/14	14/14	14/14	14/14
	5.2	Lift speed, laden/unladen	(m/s)	0.61/0.81	0.59/0.81	0.5/0.7	0.48/0.7	0.45/0.7
	5.3	Lowering speed, laden/unladen	(m/s)	XC4:0.52/0.52 XC4D:0.56/0.56	XC4:0.52/0.52 XC4D:0.56/0.56	XC4:0.52/0.52 XC4D:0.56/0.56	XC4:0.52/0.52 XC4D:0.56/0.56	XC4:0.52/0.52 XC4D:0.56/0.56
	5.4	Traverse speed w. / w.o. load	(m/s)	0.24/0.24	0.24/0.24	0.2/0.2	0.2/0.2	0.2/0.2
	5.8	Max. gradeability, laden/unladen 5min	(%)	10.0/15.0	10.0/15.0	10.0/15.0	10.0/15.0	10.0/15.0
	5.10	Service brake		Electromagnetic	Electromagnetic+Mech.	Electromagnetic+Mech.	Electromagnetic+Mech.	Electromagnetic+Mech.
Electric-engine	6.1	Drive motor rating S2 60 min.	(kW)	8.1	8.1	8.1	8.1	8.1
	6.2	Lift motor rating at S3 15%	(kW)	20	20	20	20	20
	6.3	Battery as per DIN 43531 /35/36 A, B, C, no		no	no	no	no	no
	6.4	Battery voltage, nominal capacity	(V/Ah)	80/250	80/250	80/250	80/250	80/250
	6.4.1	Battery voltage, rated capacity, Optional	(V/Ah)	80/404	80/404	80/404	80/404	80/404
6.5	Battery weight (+5%)	(kg)	275	275	275	360	360	
Addition data	10.1	Operating pressure for attachments	(bar)	150	150	150	150	150
	10.2	Oil flow for attachments	(l/min)	18	18	18	18	18
	10.7	Sound pressure level LpAZ (at the driver's seat)	(db(A))	68	68	68	68	68

Note: 1) h3>7000mm:-25mm. 2) h3>7000mm:-8mm. 3) h3>7000mm:+25mm. 4) h3>7000mm:-33mm. 5) h3>7000mm:+19mm. 6) h3>7000mm:+23mm. 7) With optional battery 80V/404Ah,h3>7000mm:-90mm.
 8) With optional battery 80V/404Ah, h3>7000mm: +90mm. 9) With optional battery 80V/404Ah, h3>7000mm: +68mm. 10) With optional battery 80V/404Ah, h3>7000mm: +82mm. 11) With optional battery 80V/404Ah,h3>7000mm:-115mm.
 12) With optional battery 80V/404Ah, h3>7000mm: +115mm. 13) With optional battery 80V/404Ah, h3>7000mm: -123mm. 14) With optional battery 80V/404Ah, h3>7000mm: +87mm. 15) With optional battery 80V/404Ah, h3>7000mm: +105mm.
 16) With optional battery 80V/404Ah:-90mm. 17) With optional battery 80V/404Ah: +90mm. 18) With optional battery 80V/404Ah: +67mm. 19) With optional battery 80V/404Ah: +81m. 20) h3>12000mm:-150mm. 21) h3>12000mm:+150mm.
 22) h3>12000mm:+115mm. 23) h3>12000mm:+137mm. 24) h3>12000mm:+105mm. 25) h3>12000mm:+134mm. 26) With optional Full free triple mast:35×100×1150.
 ★ CE model

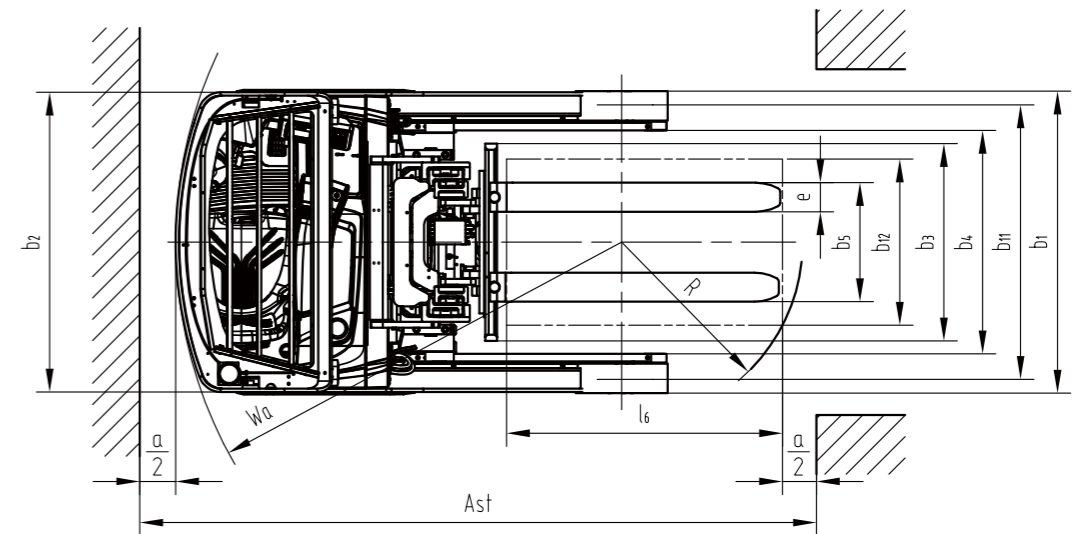
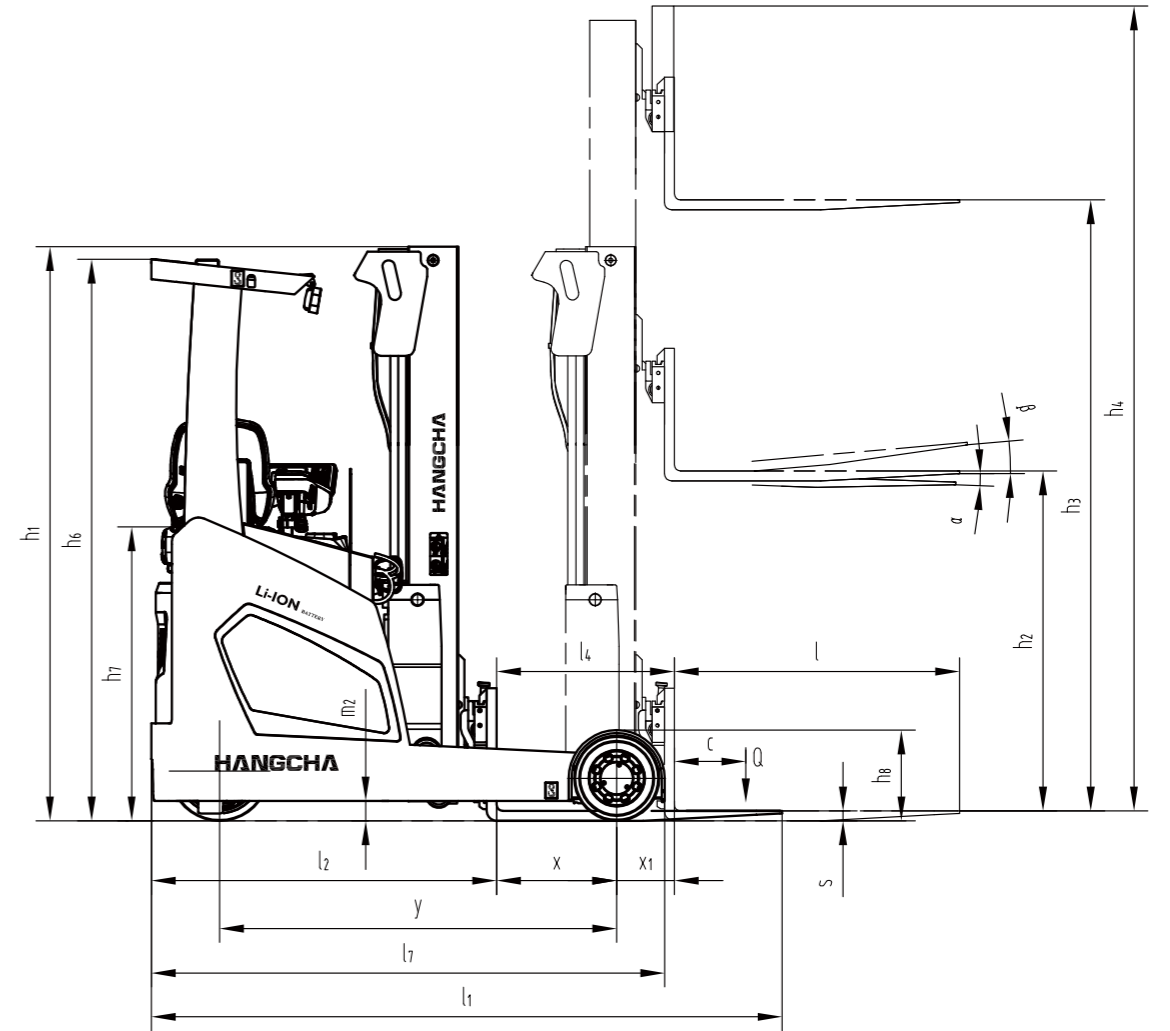

$$A_{st} = W_a + R + a = W_a + \sqrt{(l_6 - x)^2 + \left(\frac{b_{12}}{2}\right)^2} + a$$

XC Series Reach Truck With Cab Specification

Distinguishing mark	HANGCHA GROUP CO.,LTD.						
	1.1	Manufacturer					
1.2	Model		C0014-XC5-SUS* C0014-XC50-SUS*	C0016-XC5-SUS* C0016-XC50-SUS*	C0018-XC5-SUS* C0018-XC50-SUS*	C0020-XC5-SUS* C0020-XC50-SUS*	C0025-XC5-SUS* C0025-XC50-SUS*
1.3	Power unit		Li-ION battery	Li-ION battery	Li-ION battery	Li-ION battery	Li-ION battery
1.4	Manual		Seated	Seated	Seated	Seated	Seated
1.5	Rated capacity/rated load	Q(t)	1.4	1.6	1.8	2	2.5
1.6	Load centre distance	c(mm)	600	600	600	600	600
1.8	Load distance	x(mm)	282 ⁽⁷⁾¹¹⁾	332 ⁽⁷⁾¹¹⁾	307 ⁽¹¹⁾	362 ⁽²¹⁾	484 ⁽²¹⁾
1.8.1	Load distance, mast reached forward	x1(mm)	2112)	2112)	203	232	232
1.9	Wheelbase	y(mm)	1355	1405	1405	1471	1601
2.1.1	Net weight incl. battery (see row 6.5)	(kg)	3480	3500	3500	3600	3681
3.1	Tyres		PU	PU	PU	PU	PU
3.2	Tyre size, front		φ343×140	φ343×140	φ343×140	φ343×140	φ400×160
3.3	Tyre size, rear		φ285×100	φ285×100	φ285×100	φ343×108	φ343×108
3.5	Wheels, number front/rear (x = driven wheels)		1x/2	1x/2	1x/2	1x/2	1x/2
3.7	Tread width, rear	b1(mm)	1174	1174	1174	1162	1162
4.1	Tilt of fork carriage forward/backward	α/β(°)	2.0/5.0	2.0/5.0	2.0/5.0	2.0/5.0	2.0/5.0
4.2	Height, mast lowered	h1(mm)	2100	2100	2100	2100	2100
4.3	Free lift	h2(mm)	105	105	110	110	110
4.4	Lift	h3(mm)	3000	3000	3000	3000	3000
4.5	Height, mast extended	h4(mm)	3965	3965	3965	3965	3965
4.7	Height of overhead guard	he(mm)	2264	2264	2264	2264	2264
4.8	Seat height	hf(mm)	1159	1159	1159	1159	1159
4.10	Height of support arms	he1(mm)	307.5	307.5	365.5	365.5	365.5
4.19	Overall length	l1(mm)	2558 ⁽¹⁹⁾²²⁾	2558 ⁽¹⁹⁾²²⁾	2583 ⁽¹⁹⁾	2584 ⁽¹⁹⁾	2622 ⁽²¹⁾
4.20	Length to face of forks	l2(mm)	1408 ⁽¹⁹⁾²²⁾	1408 ⁽¹⁹⁾²²⁾	1433 ⁽¹⁹⁾	1444 ⁽¹⁹⁾	1472 ⁽²¹⁾
4.21	Overall width	b1/b2(mm)	1270/1270	1270/1270	1270/1270	1270/1270	1270/1270
4.22	Fork dimensions	s/e/l(mm)	40×122×1150 ⁽²¹⁾	40×122×1150 ⁽²¹⁾	40×122×1150	40×122×1150	40×122×1150
4.23	Fork carriage ISO 2328, class/type A, B		II A	II A	II A	II A	II A
4.24	Fork-carriage width	b3(mm)	830	830	830	830	830
4.25	Distance between fork-arms	b5(mm)	750	750	750	750	750
4.26	Distance between wheel arms	b4(mm)	940	940	940	940	940
4.28	Reach distance	l4(mm)	493 ⁽¹⁷⁾²¹⁾	543 ⁽¹⁷⁾²¹⁾	510 ⁽¹⁸⁾	584 ⁽²¹⁾	716 ⁽²¹⁾
4.32	Ground clearance, centre of wheelbase	m2(mm)	80	80	80	80	80
4.33	Aisle width for pallets 1000 × 1200 sideways	A4s(mm)	2826 ⁽¹⁹⁾⁴⁾	2838 ⁽¹⁹⁾⁴⁾	2857 ⁽¹⁹⁾	2882 ⁽²¹⁾	2947 ⁽²¹⁾
4.34	Aisle width for pallets 800 × 1200 lengthways	A4l(mm)	2893 ⁽¹⁹⁾¹⁵⁾	2896 ⁽¹⁹⁾¹⁵⁾	2918 ⁽¹⁹⁾	2935 ⁽²¹⁾	2976 ⁽²¹⁾
4.35	Turning radius	Wa(mm)	1690	1740	1740	1806	1956
4.37	Length over the support arms	l7(mm)	1855	1905	1905	2000	2150
5.1	Travel speed, laden/unladen	(km/h)	14/14	14/14	14/14	14/14	14/14
5.2	Lift speed, laden/unladen	(m/s)	0.61/0.81	0.59/0.81	0.5/0.7	0.48/0.7	0.45/0.7
5.3	Lowering speed, laden/unladen	(m/s)	XC4:0.52/0.52 XC4D:0.56/0.56	XC4:0.52/0.52 XC4D:0.56/0.56	XC4:0.52/0.52 XC4D:0.56/0.56	XC4:0.52/0.52 XC4D:0.56/0.56	XC4:0.52/0.52 XC4D:0.56/0.56
5.4	Traverse speed w./ w.o. load	(m/s)	0.24/0.24	0.24/0.24	0.2/0.2	0.2/0.2	0.2/0.2
5.8	Max. gradeability, laden/unladen 5min	(%)	10.0/15.0	10.0/15.0	10.0/15.0	10.0/15.0	10.0/15.0
5.10	Service brake		Hydr./Mech.	Hydr./Mech.	Hydr./Mech.	Hydr./Mech.	Hydr./Mech.
6.1	Drive motor rating S2 60 min.	(kW)	8.1	8.1	8.1	8.1	8.1
6.2	Lift motor rating at S3 15%	(kW)	20	20	20	20	20
6.3	Battery as per DIN 43531/35/36 A, B, C, no		no	no	no	no	no
6.4	Battery voltage, nominal capacity	(V/Ah)	80/250	80/250	80/250	80/250	80/250
6.4.1	Battery voltage, rated capacity, Optional	(V/Ah)	80/404	80/404	80/404	80/404	80/404
6.5	Battery weight (+5%)	(kg)	275	275	275	275	275
10.1	Operating pressure for attachments	(bar)	150	150	150	150	150
10.2	Oil flow for attachments	(l/min)	18	18	18	18	18
10.7	Sound pressure level LpAZ (at the driver's seat)	(db(A))	75	75	75	75	75

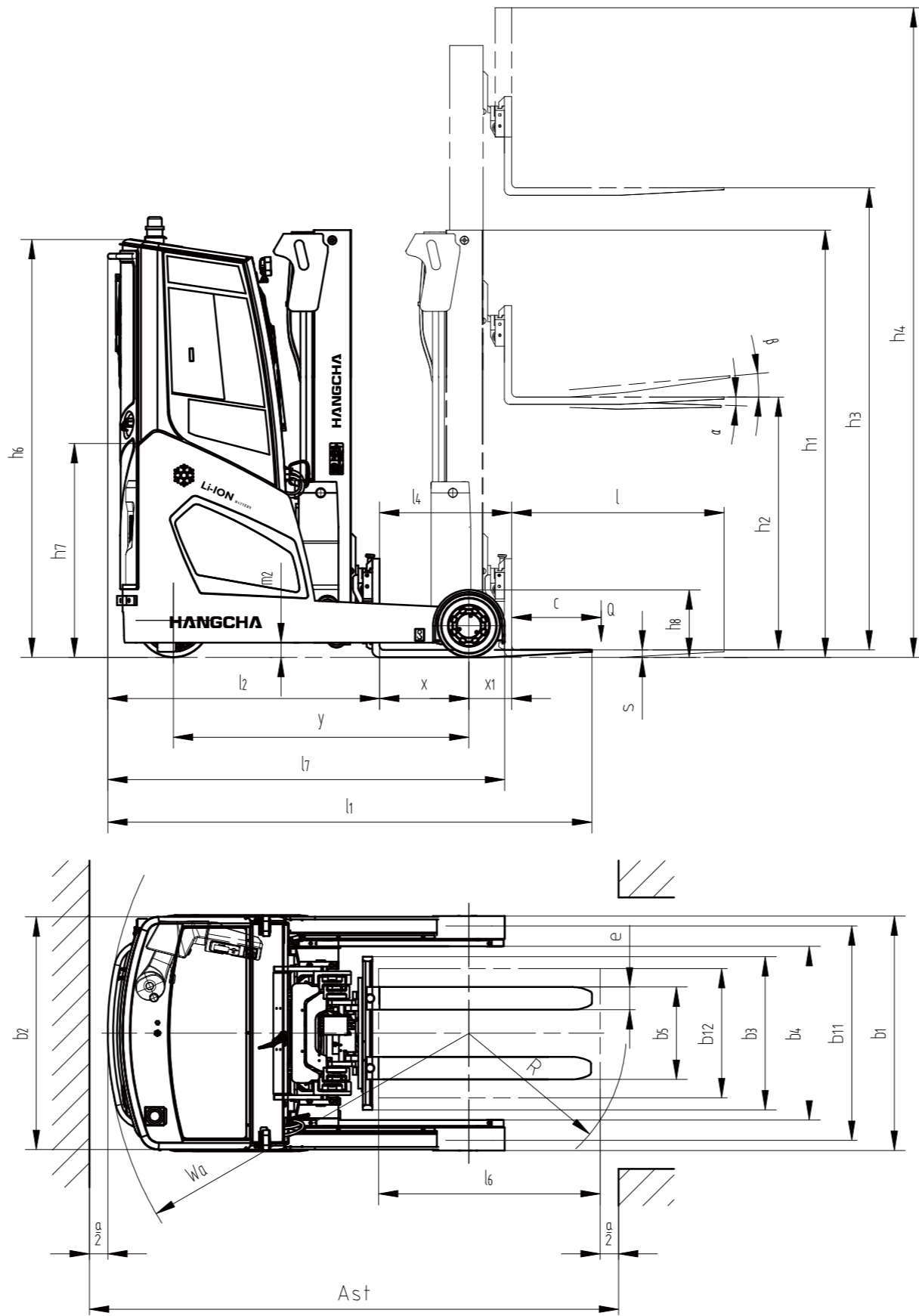

$$Ast = Wa + R + a = Wa + \sqrt{(l6 - x)^2 + \left(\frac{b12}{2}\right)^2} + a$$

Note: 1) h3>7000mm:-25mm. 2) h3>7000mm:-8mm. 3) h3>7000mm:+25mm. 4) h3>7000mm:-33mm. 5) h3>7000mm:-19mm. 6) h3>7000mm:+23mm. 7) With optional battery 80V/404Ah,h3>7000mm:-12mm.
 8) With optional battery 80V/404Ah, h3>7000mm: +12mm. 9) With optional battery 80V/404Ah, h3>7000mm: +9mm. 10) With optional battery 80V/404Ah, h3>7000mm: +11mm. 11) With optional battery 80V/404Ah, h3>7000mm: +35mm.
 12) With optional battery 80V/404Ah, h3>7000mm: +35mm. 13) With optional battery 80V/404Ah, h3>7000mm: -45mm. 14) With optional battery 80V/404Ah, h3>7000mm: +28mm. 15) With optional battery 80V/404Ah, h3>7000mm: +34mm.
 16) With optional battery 80V/404Ah:-12mm. 17) With optional battery 80V/404Ah: +12mm. 18) With optional battery 80V/404Ah: +9mm. 19) With optional battery 80V/404Ah: +11m. 20) h3>12000mm:-150mm. 21) h3>12000mm:+150mm.
 22) h3>12000mm:+115mm. 23) h3>12000mm:+137mm. 24) h3>12000mm:+105mm. 25) h3>12000mm:+134mm; 26) With optional Full free tripe mast:35×100×1150.
 ★ CE model

1.4t Residual Load Capacity Chart

Capacity(kg)	Load center distance(mm)							
	600	700	800	900	1000	1100	1200	
≤6000	1400	1210	1070	920	780	660	550	
6500	1300	1120	990	840	720	600	490	
7000	1200	1030	910	770	650	540	430	
7500	1100	940	830	700	580	470	370	
8000	1050	900	790	660	550	440	350	
8500	1000	850	750	620	510	410	320	
9000	900	770	670	550	450	350	260	
9500	800	680	590	480	380	290	200	
10000	700	590	510	400	310	230	150	
10500	550	450	390	300	210	130	60	
11000	350	280	230	150	80	10	0	

1.6t Residual Load Capacity Chart

Capacity(kg)	Load center distance(mm)							
	600	700	800	900	1000	1100	1200	
≤6000	1600	1390	1230	1060	920	780	660	
6500	1500	1300	1150	990	850	720	610	
7000	1400	1210	1070	920	780	660	550	
7500	1300	1120	990	840	710	600	490	
8000	1250	1080	950	810	680	570	460	
8500	1200	1030	910	770	650	530	430	
9000	1100	940	830	700	580	470	370	
9500	1000	850	750	620	510	410	320	
10000	900	770	670	550	450	350	260	
10500	750	630	550	440	350	260	170	
11000	550	450	390	300	210	130	60	

1.8t Residual Load Capacity Chart

Capacity(kg)	Load center distance(mm)							
	600	700	800	900	1000	1100	1200	
≤6000	1800	1570	1390	1210	1050	900	780	
6500	1700	1480	1310	1130	980	840	720	
7000	1600	1390	1230	1060	910	780	660	
7500	1500	1300	1150	990	850	720	600	
8000	1450	1250	1110	950	810	690	570	
8500	1400	1210	1070	910	780	660	550	
9000	1300	1120	990	840	710	600	490	
9500	1200	1030	910	770	650	530	430	
10000	1100	940	830	700	580	470	370	
10500	950	810	710	590	480	380	290	
11000	750	630	550	440	350	260	170	
11500	550	450	390	300	210	130	60	

2.0t Residual Load Capacity Chart

Capacity(kg)	Load center distance(mm)							
	600	700	800	900	1000	1100	1200	
≤6500	2000	1750	1560	1360	1200	1040	910	
7000	1950	1710	1520	1330	1160	1010	880	
7500	1850	1620	1440	1250	1090	950	820	
8000	1800	1570	1400	1220	1060	920	790	
8500	1750	1530	1360	1180	1030	890	760	
9000	1650	1440	1280	1110	960	830	700	
9500	1550	1350	1190	1030	890	760	650	
10000	1450	1260	1110	960	820	700	590	
10500	1300	1130	990	850	720	610	500	
11000	1000	860	750	630	520	420	330	
11500	800	680	590	480	390	290		